

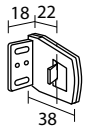

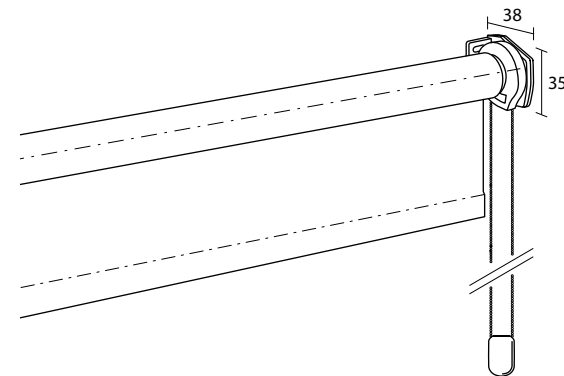

SLIM 17

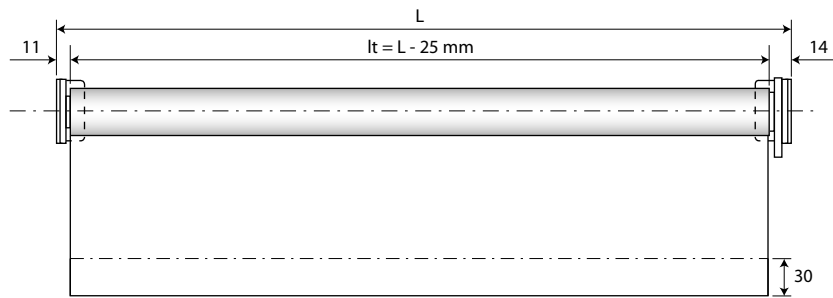

Cod. 609A05...SX / DX
Sistema a parete/soffitto
Wall/Ceiling system

Cod. 609T05...SX / DX
Système de face/plafond
Wand-/Deckensystem

Sistema pared/techo
System ścienny/sufitowy

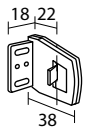
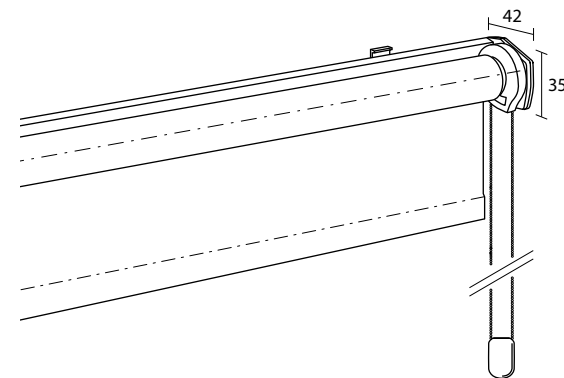
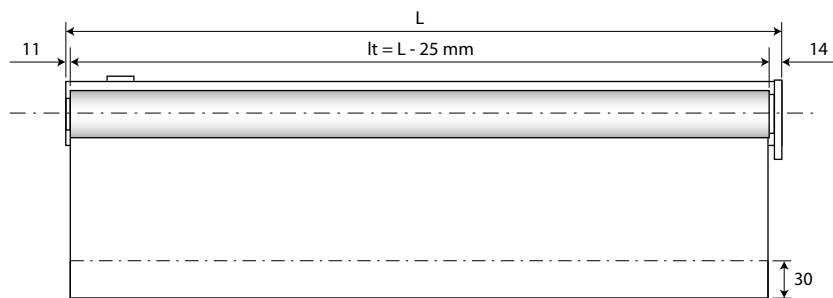

Cod. 609G05...SX / DX
Sistema a parete/soffitto con barra portarullo
Wall/Ceiling system with fixing bar

Cod. 679S05...SX / DX
Système de face/plafond avec barre de fixation
Wand-/Deckensystem mit Rollenhaltestange

Sistema pared/techo con barra de fijación
System ścienny / sufitowy z rolką



86



87

L = Larghezza sistema (cm) - System width (cm) - Largeur système (cm) - Gesamtbreite (cm) - Ancho sistema (cm) - Szerokość systemu (cm)
lt = Larghezza singolo tessuto - Fabric width per unit - Largeur chaque toile - Stoff Breite - Ancho de cada tejido - Szerokość pojedynczej tkaniny



FIN 86 - 87

Supporti - Brackets - Supports - Träger - Soportes - Wsporniki Cod. 609405

L - cm CT	40						50					
	A	B	C	D	E	F	A	B	C	D	E	F
60												
80												
100												
120												
140												

L - cm CT	60						70					
	A	B	C	D	E	F	A	B	C	D	E	F
60												
80												
100												
120												
140												

Spessore tessuto non superiore a 0,5 mm - Fabric thickness not exceeding 0,5 mm - Épaisseur tissu pas supérieur à 0,5 mm
 Gewebestärke nicht über 0,5 mm - Grosor tejido no superior a 0,5 mm - Grubość tkaniny nieprzekraczająca 0,5 mm

Barra portarullo - Fixing bar - Barre de fixation - Rollenhalterungsstange - Barra de fijación - Walek rolety

L - cm CT	40						50					
	A	B	C	D	E	F	A	B	C	D	E	F
60												
80												
100												
120												
140												

L - cm CT	60						70					
	A	B	C	D	E	F	A	B	C	D	E	F
60												
80												
100												
120												
140												

Spessore tessuto non superiore a 0,5 mm - Fabric thickness not exceeding 0,5 mm - Épaisseur tissu pas supérieur à 0,5 mm
 Gewebestärke nicht über 0,5 mm - Grosor tejido no superior a 0,5 mm - Grubość tkaniny nieprzekraczająca 0,5 mm

FIN = Finitura - Finish - Finition - Fertigung - Acabado - Wykończenie

L = Larghezza sistema (cm) - System width (cm) - Largeur système (cm) - Gesamtbreite (cm) - Ancho sistema (cm) - Szerokość systemu (cm)

CT = Classe tessuto - Fabric category - Catégorie tissu - Gewebegruppe - Categoría tejido - Klasa tkaniny

C = Altezza tessuto (cm) - Fabric height (cm) - Hauteur de la toile (cm) - Stoff Höhe (cm) - Altura tejido (cm) - Wysokość tkaniny (cm)

SLIM 25

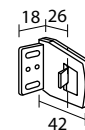
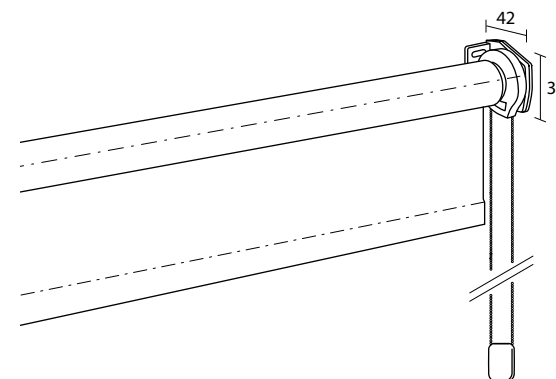
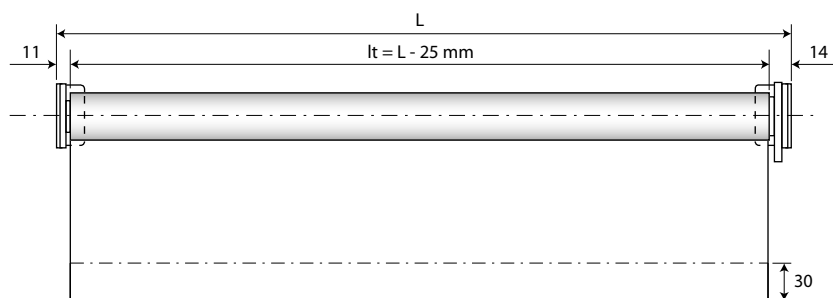

Cod. 679A05...SX / DX
Sistema a parete/soffitto
Wall/Ceiling system

Cod. 679S05...SX / DX
Système de face/plafond
Wand-/Deckensystem

Sistema pared/techo
System ścienny/sufitowy

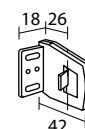
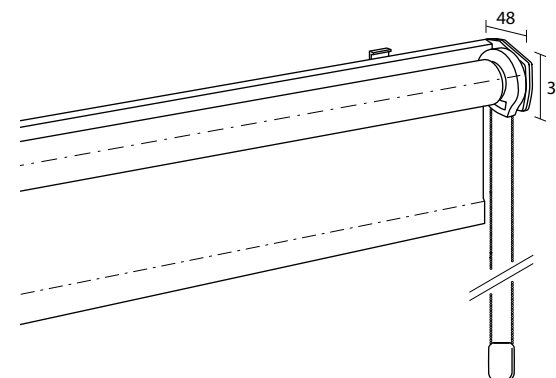
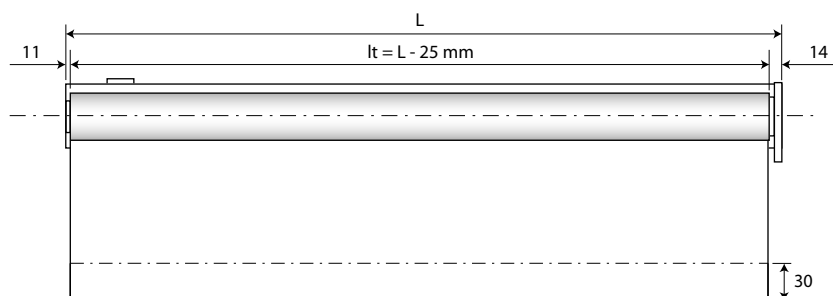

Cod. 679G05...SX / DX
Sistema a parete/soffitto con barra portarullo
Wall/Ceiling system with fixing bar

Cod. 679T05...SX / DX
Système de face/plafond avec barre de fixation
Wand-/Deckensystem mit Rollenhaltestange

Sistema pared/techo con barra de fijación
System ścienny / sufitowy z rolką



18



86



87

L = Larghezza sistema (cm) - System width (cm) - Largeur système (cm) - Gesamtbreite (cm) - Ancho sistema (cm) - Szerokość systemu (cm)
lt = Larghezza singolo tessuto - Fabric width per unit - Largeur chaque toile - Stoff Breite - Ancho de cada tejido - Szerokość pojedynczej tkaniny



FIN 18 - 86 - 87

Supporti - Brackets - Supports - Träger - Soportes - Wsporniki Cod. 679415

L - cm CT	60						80						100					
	A	B	C	D	E	F	A	B	C	D	E	F	A	B	C	D	E	F
80																		
100																		
120																		
140																		
160																		
180																		

L - cm CT	120											
	A	B	C	D	E	F	A	B	C	D	E	F
80												
100												
120												
140												
160												
180												

Spessore tessuto non superiore a 0,5 mm - Fabric thickness not exceeding 0,5 mm - Épaisseur tissu pas supérieur à 0,5 mm
 Gewebestärke nicht über 0,5 mm - Grosor tejido no superior a 0,5 mm - Grubość tkaniny nieprzekraczająca 0,5 mm

Barra portarullo - Fixing bar - Barre de fixation - Rollenhalterungsstange - Barra de fijación - Walek rolety

L - cm CT	60						80						100					
	A	B	C	D	E	F	A	B	C	D	E	F	A	B	C	D	E	F
80																		
100																		
120																		
140																		
160																		
180																		

L - cm CT	120						140					
	A	B	C	D	E	F	A	B	C	D	E	F
80												
100												
120												
140												
160												
180												

Spessore tessuto non superiore a 0,5 mm - Fabric thickness not exceeding 0,5 mm - Épaisseur tissu pas supérieur à 0,5 mm
 Gewebestärke nicht über 0,5 mm - Grosor tejido no superior a 0,5 mm - Grubość tkaniny nieprzekraczająca 0,5 mm

Maggiorazioni - Surcharges - Suppléments - Zuschläge - Suplementos - Dodatkowa opłata

N&D

Guide nylon - Nylon giude - Guidage nylon - Gleitkabel aus Nylon - Guías nylon - Prowadnicami nylonowymi

FIN = Finitura - Finish - Finition - Fertigung - Acabado - Wykończenie
 L = Larghezza sistema (cm) - System width (cm) - Largeur système (cm) - Gesamtbreite (cm) - Ancho sistema (cm) - Szerokość systemu (cm)
 CT = Classe tessuto - Fabric category - Catégorie tissu - Gewebegruppe - Categoría tejido - Klasa tkaniny
 C = Altezza tessuto (cm) - Fabric height (cm) - Hauteur de la toile (cm) - Stoff Höhe (cm) - Altura tejido (cm) - Wysokość tkaniny (cm)

SLIM 17 - 25

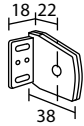

609406

Lato Perno Slim 17
Pivot Side Slim 17
Côté Pivot Slim 17
Träger Achseseite Slim 17
Lado pivote Slim 17
Strona czopa Slim 17

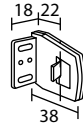

609405

Lato catena Slim 17
Chain side Slim 17
Côté chainette Slim 17
Träger Ketteseite Slim 17
Lado cadena Slim 17
Strona łańcuszka Slim 17

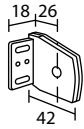

679416

Lato Perno Slim 25
Pivot Side Slim 25
Côté Pivot Slim 25
Träger Achseseite Slim 25
Lado pivote Slim 25
Strona czopa Slim 25

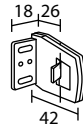

679415

Lato catena Slim 25
Chain side Slim 25
Côté chainette Slim 25
Träger Ketteseite Slim 25
Lado cadena Slim 25
Strona łańcuszka Slim 25

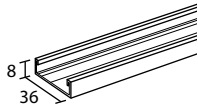

663899

Barra portarullo
Fixing bar
Barre de fixation
Rollenhalterungsstange
Barra de fijación
Wałek do rolety

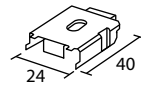

1055

Molla di fissaggio
Fixing spring
Ressort de fixation
Befestigungsfeder
Muelle de fijación
Mocowanie

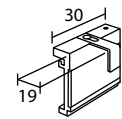

123024

Aggancio ausiliario per binario
Auxiliary hanger for tracks
Support pour chemin de fer
Hilfskoppelung für Schiene
Engancho auxiliar para riel
Dodatkowe zahaczenie dla szyny

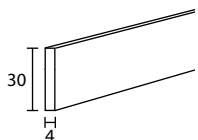

303190

Peso interno
Internal weight
Barre de lestage interne

Interne Beschwerungsprofil
Perfil contrapeso interior
Obciążnik wewnętrzny

COMPONENTI - COMPONENTS - COMPOSANTS - ZUBEHÖR - COMPONENTES - CZĘŚCI

Cod.	609406SX / DX	609405SX / DX
FIN		
18 - 86 - 87		

Cod.	679416SX / DX	679415SX / DX
FIN		
18 - 86 - 87		

Cod.	663899	1055
FIN	L - mt	1
18 - 86 - 87		

Cod.	123024
FIN	
18 - 86 - 87	

Cod.	303190
FIN	L - mt
	1

SLIM 17 - 25

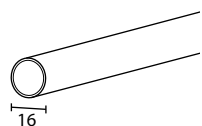

164100

Peso
Weight bar
Barre de lestage

Beschwerungsprofil
Perfil contrapeso
Obciążnik

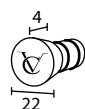

163055

Tappo per peso
Endcap for weight bar
Bouchon pour barre de lestage
Endkappe Für Beschwerungsprofil
Tapón para contrapeso
Zaślepka obciążnika



163245

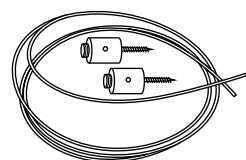

2355

Cavo laterale con fermo verticale
Side cable with vertical stop
Câble latéral avec arrêt vertical
Seitenkabel mit vertikaler Sperre
Cable lateral con tope vertical
Przewód boczny z ogranicznikiem pionowym

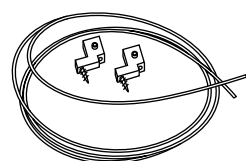

2356

Cavo laterale con fermo orizzontale
Side cable with horizontal stop
Câble latéral avec arrêt horizontal
Seitenkabel mit horizontaler Sperre
Cable lateral con tope horizontal
Przewód boczny z ogranicznikiem poziomym

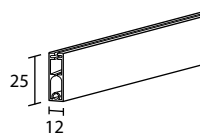

253120

Peso
Weight bar
Barre de lestage
Beschwerungsprofil
Perfil contrapeso
Obciążnik



253135

Tappo per peso
Endcap for weight bar
Bouchon pour barre de lestage
Endkappe Für Beschwerungsprofil
Tapón para contrapeso
Zaślepka obciążnika

COMPONENTI - COMPONENTS - COMPOSANTS - ZUBEHÖR - COMPONENTES - CZĘŚCI

Cod.		164100
FIN	L - mt	1
18 - 25		

Cod.	163055	163245
FIN		
18 - 25		
67		

Cod.	2355
FIN	

Cod.	2356
FIN	

Cod.	253120	253135
FIN	L - mt	1
18 - 86 - 87		