

Cod. 833X59...SX / DX

Sistema a parete
Wall system

Système de face
Wandmontage

Sistema pared
System ścienny

Cod.	833459SX / DX	833449SX / DX
A - mm	147	182
H - mm	120	155
K - mm	67	102

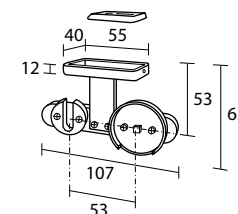
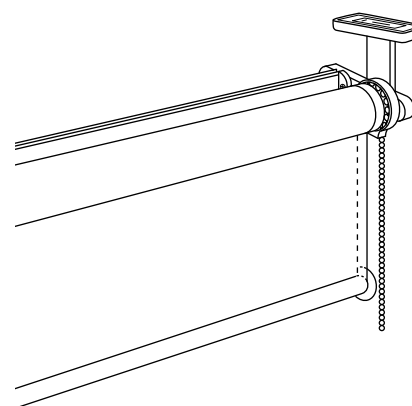
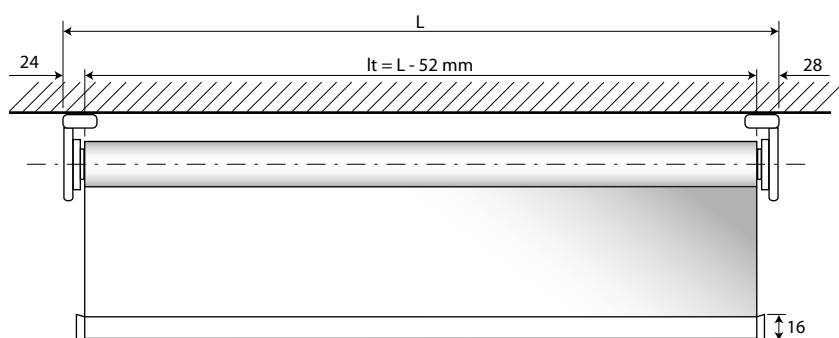

Cod. 833U69...SX / DX

Sistema a soffitto
Ceiling system

Système plafond
Deckenmontage

Sistema techo
System sufitowy



25



67



312

A = Sporgenza supporto - Bracket's projection - Retour support - Träger Abstand - Escuadra de separación - Występ wspornika
H = Distanza parete - Wall distance - Retour du mur - Wand Abstand - Distancia pared - Odległość od ściany
L = Larghezza sistema (cm) - System width (cm) - Largeur système (cm) - Gesamtbreite (cm) - Ancho sistema (cm) - Szerokość systemu (cm)
lt = Larghezza singolo tessuto - Fabric width per unit - Largeur chaque toile - Stoff Breite - Ancho de cada tejido - Szerokość pojedynczej tkaniny

FIN 25 - 312

Supporti - Brackets - Supports - Träger - Soportes - Wsporniki Cod. 833419 - 833429

L - cm CT	80			100			120			140		
	D	E	F	D	E	F	D	E	F	D	E	F
120												
140												
160												
180												
200												
220												
240												
260												
280												
300												

L - cm CT	160			180			200		
	D	E	F	D	E	F	D	E	F
120									
140									
160									
180									
200									
220									
240									
260									
280									
300									

Spessore tessuto non superiore a 0,5 mm - Fabric thickness not exceeding 0,5 mm

Épaisseur tissu pas supérieur à 0,5 mm - Gewebestärke nicht über 0,5 mm

Grosor tejido no superior a 0,5 mm - Grubość tkaniny nieprzekraczająca 0,5 mm

Rullo in acciaio Ø 25 fino a 160 cm / Rullo in alluminio Ø 34 oltre 160 cm - Steel tube Ø 25 up to 160 cm / Aluminium tube Ø 34 over 160 cm

Tube acier Ø 25 jusqu'à 160 cm / Tube aluminium Ø 34 au-delà 160 cm - Stahlrolle Ø 25 mm bis 160 cm / Aluminiumrolle Ø 34 mm über 160 cm

Tubo de acero Ø 25 hasta 160 cm / Tubo de aluminio Ø 34 arriba 160 cm - Roleta stalowa Ø 25 do 160 cm / Roleta aluminiowa Ø 34 od ponad 160 cm

Maggiorazioni - Surcharges - Suppléments - Zuschläge - Suplementos - Dodatkowa opłata

67	
----	--

FIN = Finitura - Finish - Finition - Fertigung - Acabado - Wykończenie

L = Larghezza sistema (cm) - System width (cm) - Largeur système (cm) - Gesamtbreite (cm) - Ancho sistema (cm) - Szerokość systemu (cm)

CT = Classe tessuto - Fabric category - Catégorie tissu - Gewebegruppe - Categoría tejido - Klasa tkaniny

C = Altezza tessuto (cm) - Fabric height (cm) - Hauteur de la toile (cm) - Stoff Höhe (cm) - Altura tejido (cm) - Wysokość tkaniny (cm)

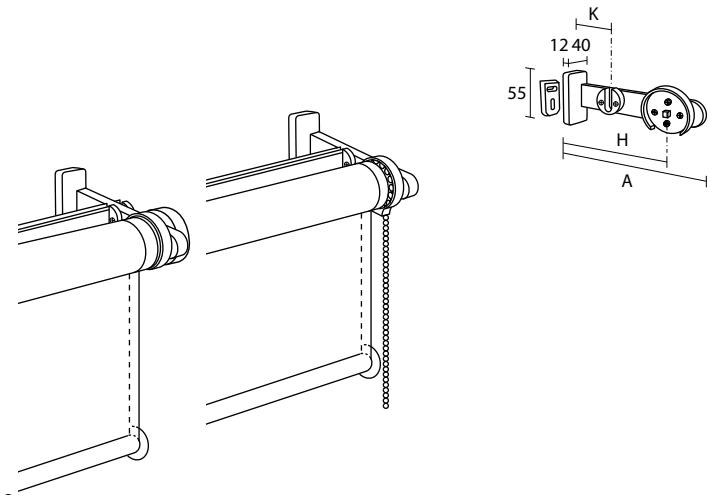
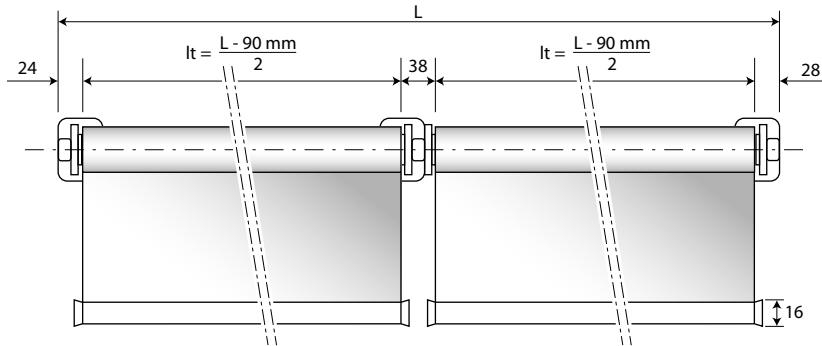

Cod. 833B14...SX / DX

Sistema continuo a parete
Wall consecutive system

Système continu de face
Wandsystem mit Seite an Seite Stoffen

Sistema pared continuo
System ścienny ciągły

Cod.	833459SX / DX	833449SX / DX
A - mm	147	182
H - mm	120	155
K - mm	67	102

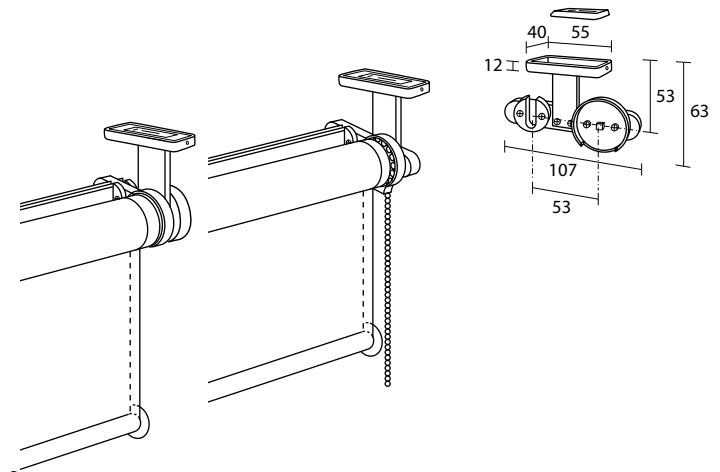
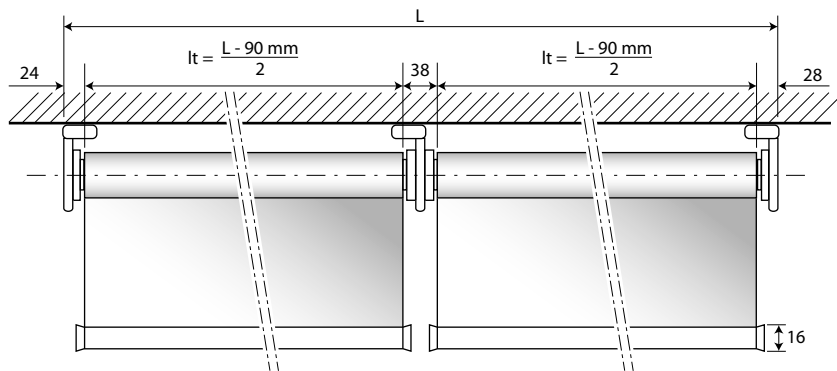

Cod. 833W24

Sistema continuo a soffitto
Ceiling consecutive system

Système continu plafond
Deckensystem mit Seite an Seite Stoffen

Sistema continuo techo
System sufitowy ciągły



25



67



312

A = Sporgenza supporto - Bracket's projection - Retour support - Träger Abstand - Escuadra de separación - Występowspornika
H = Distancia parete - Wall distance - Retour du mur - Wand Abstand - Distancia pared - Odległość od ściany
L = Larghezza sistema (cm) - System width (cm) - Largeur système (cm) - Gesamtbreite (cm) - Ancho sistema (cm) - Szerokość systemu (cm)
lt = Larghezza singolo tessuto - Fabric width per unit - Largeur chaque toile - Stoff Breite - Ancho de cada tejido - Szerokość pojedynczej tkaniny

FIN 25 - 312

Supporti - Brackets - Supports - Träger - Soportes - Wsporniki Cod. 833419 - 833429

L - cm CT	160			200			240			280		
	D	E	F	D	E	F	D	E	F	D	E	F
120	C - cm											
140												
160												
180												
200												
220												
240												
260												
280												
300												

L - cm CT	320			360			400			
	D	E	F	D	E	F	D	E	F	
120	C - cm									
140										
160										
180										
200										
220										
240										
260										
280										
300										

Spessore tessuto non superiore a 0,5 mm - Fabric thickness not exceeding 0,5 mm

Épaisseur tissu pas supérieur à 0,5 mm - Gewebestärke nicht über 0,5 mm

Grosor tejido no superior a 0,5 mm - Grubość tkaniny nieprzekraczająca 0,5 mm

Rullo in acciaio Ø 25 fino a 160 cm / Rullo in alluminio Ø 34 oltre 160 cm - Steel tube Ø 25 up to 160 cm / Aluminium tube Ø 34 over 160 cm

Tube acier Ø 25 jusqu'à 160 cm / Tube aluminium Ø 34 au-delà 160 cm - Stahlrolle Ø 25 mm bis 160 cm / Aluminiumrolle Ø 34 mm über 160 cm

Tubo de acero Ø 25 hasta 160 cm / Tubo de aluminio Ø 34 arriba 160 cm - Roleta stalowa Ø 25 do 160 cm / Roleta aluminiowa Ø 34 od ponad 160 cm

È possibile realizzare dei sistemi Night & Day continui a 2 teli mantenendo l'allineamento delle fasce con un supplemento di Euro 90,00 a sistema.

It is possible to produce Night & Day consecutive systems with 2 fabrics keeping the stripes aligned with an upcharge of € 90,00 per system.

Il est possible de réaliser des systèmes continus Night & Day à 2 toiles en gardant les bandes alignées avec un supplément de € 90,00 par système.

Die Systeme Night & Day lassen sich gegen einen Aufpreis von 90,00 Euro mit 2 ununterbrochenen Vorhängen realisieren. Hierbei bleibt die Ausrichtung der Bänder erhalten.

Es posible producir sistemas continuos Night & Day a 2 telas manteniendo las rayas alineadas con un suplemento de € 90,00 por sistema.

W przypadku systemów dwuwarstwowych rolet Night & Day zestawionych obok siebie istnieje możliwość wyrównania układu pasów za dodatkową opłatą w wysokości 90,00 Euro za każdy system.

Maggiorazioni - Surcharges - Suppléments - Zuschläge - Suplementos - Dodatkowa opłata

67

FIN = Finitura - Finish - Finition - Fertigung - Acabado - Wykończenie

L = Larghezza sistema (cm) - System width (cm) - Largeur système (cm) - Gesamtbreite (cm) - Ancho sistema (cm) - Szerokość systemu (cm)

CT = Classe tessuto - Fabric category - Catégorie tissu - Gewebegruppe - Categoría tejido - Klasa tkaniny

C = Altezza tessuto (cm) - Fabric height (cm) - Hauteur de la toile (cm) - Stoff Höhe (cm) - Altura tejido (cm) - Wysokość tkaniny (cm)

COMETA

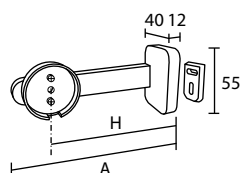

8334--

Lato perno
Pivot side
Côté pivot

Träger Achseseite
Lado pivote
Strona czopa

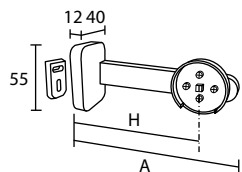

8334--

Lato catena
Chain side
Côté chainette

Träger Ketteseite
Lado cadena
Strona łańcuszka

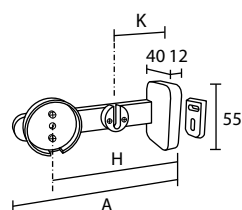

833458 833498 N&D

Lato perno
Pivot side
Côté pivot

Träger Achseseite
Lado pivote
Strona czopa

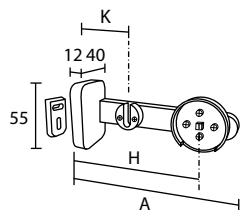

833459 833499 N&D

Lato catena
Chain side
Côté chainette

Träger Ketteseite
Lado cadena
Strona łańcuszka

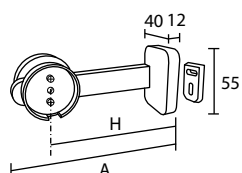

8334--

Intermedio P/P
Middle P/P
Intermédiaire P/P

Mittelträger P/P
Intermedio P/P
Środkowy P/P

P = Lato perno - Pivot side - Côté pivot - Achseseite - Lado Pivote - Strona czopa
C = Lato catena - Chain side - Côté chainette - Ketteseite - Lado cadena - Strona łańcuszka

SISTEMA A PARETE - WALL SYSTEM - SYSTÈME DE FACE - WANDMONTAGE - SISTEMA PARED - SYSTEM ŚCIENNY

Cod.		833418SX / DX	833438SX / DX	833448SX / DX
FIN	A - mm	82	132	182
	H - mm	55	105	155
25 - 312				
67				

Cod.		833419SX / DX	833439SX / DX	833449SX / DX
FIN	A - mm	82	132	182
	H - mm	55	105	155
25 - 312				
67				

Cod.		833458SX / DX N&D	833498SX / DX N&D
FIN	A - mm	147	182
	H - mm	120	155
	K - mm	67	102
25 - 312			
67			

Cod.		833459SX / DX N&D	833499SX / DX N&D
FIN	A - mm	147	182
	H - mm	120	155
	K - mm	67	102
25 - 312			
67			

Cod.		833477SX / DX	833487SX / DX	833497SX / DX
FIN	A - mm	82	132	182
	H - mm	55	105	155
25 - 312				
67				

COMETA

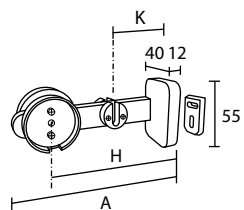

833479 833579 N&D

Intermedio P/P
Middle P/P
Intermédiaire P/P

Mittelträger P/P
Intermedio P/P
Środkowy P/P

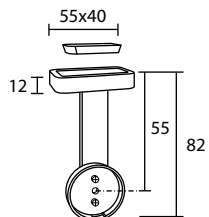

833428

Lato perno
Pivot side
Côté pivot

Träger Achseseite
Lado pivote
Strona czopa

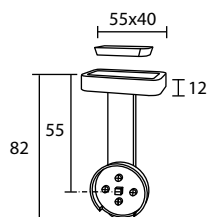

833429

Lato catena
Chain side
Côté chainette

Träger Ketteseite
Lado cadena
Strona łańcuszka

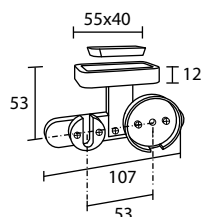

833468 N&D

Lato perno
Pivot side
Côté pivot

Träger Achseseite
Lado pivote
Strona czopa

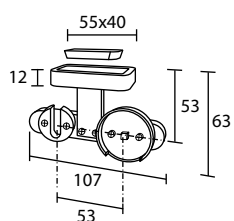

833469 N&D

Lato catena
Chain side
Côté chainette

Träger Ketteseite
Lado cadena
Strona łańcuszka

P = Lato perno - Pivot side - Côté pivot - Achseseite - Lado Pivote - Strona czopa
C = Lato catena - Chain side - Côté chainette - Ketteseite - Lado cadena - Strona łańcuszka

SISTEMA A PARETE - WALL SYSTEM - SYSTÈME DE FACE - WANDMONTAGE - SISTEMA PARED - SYSTEM ŚCIENNY

Cod.		833479SX / DX N&D	833579SX / DX N&D
FIN	A - mm	147	182
	H - mm	120	155
	K - mm	67	102
25 - 312			
67			

SISTEMA A SOFFITTO - CEILING SYSTEM - SYSTÈME PLAFOND - DECKENMONTAGE - SISTEMA TECHO - SYSTEM SUFITOWY

Cod.	833428
FIN	
25 - 312	
67	

Cod.	833429
FIN	
25 - 312	
67	

Cod.	833468 N&D
FIN	
25 - 312	
67	

Cod.	833469 N&D
FIN	
25 - 312	
67	

COMETA

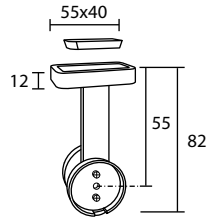

833569

Intermedio P/P
Middle P/P
Intermédiaire P/P

Mittelträger P/P
Intermedio P/P
Środkowy P/P

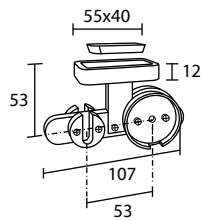

833589 N&D

Intermedio P/P
Middle P/P
Intermédiaire P/P

Mittelträger P/P
Intermedio P/P
Środkowy P/P

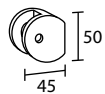

1047

Fermacatena
Chain stop
Arrêt chainette

Kettestopp
Bloque cadena
Blokada łańcuszka

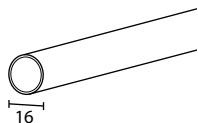

164100

Peso
Weight bar
Barre de lestage
Beschwerungsprofil
Perfil contrapeso
Obciążnik

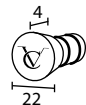

163055

Tappo per peso
Endcap for weight bar
Bouchon pour barre de lestage
Endkappe Für Beschwerungsprofil
Tapón para contrapeso
Zaślepka obciążnika

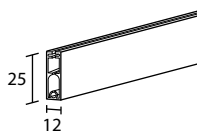

253120

Peso
Weight bar
Barre de lestage
Beschwerungsprofil
Perfil contrapeso
Obciążnik



253135

Tappo per peso
Endcap for weight bar
Bouchon pour barre de lestage
Endkappe Für Beschwerungsprofil
Tapón para contrapeso
Zaślepka obciążnika

P = Lato perno - Pivot side - Côté pivot - Achseseite - Lado Pivote - Strona czopa
C = Lato catena - Chain side - Côté chainette - Ketteseite - Lado cadena - Strona łańcuszka

SISTEMA A SOFFITTO - CEILING SYSTEM - SYSTÈME PLAFOND - DECKENMONTAGE - SISTEMATECHO - SYSTEM SUFITOWY

Cod.	833569	
FIN		
25 - 312		
67		

Cod.	833589 N&D	
FIN		
25 - 312		
67		

COMPONENTI - COMPONENTS - COMPOSANTS - ZUBEHÖR - COMPONENTES - CZĘŚCI

Cod.	1047	
FIN		
25 - 312		
67		

Cod.	164100	163055
FIN	l - mt	1
25 - 312		
67		

Cod.	253120	253135
FIN	l - mt	1
25 - 312		
67		