

Cod. 103T29...SX / DX

Sistema a soffitto con guide oscuranti per finestra incassata
 Ceiling system with blackout guides for recessed window
 Système plafond avec guides occultantes pour fenêtre encastrée
 Deckensystem mit verdunkelten Führungen für Einbaufenster
 Sistema techo con guías blackout para ventana empotrada
 System sufitowy z szynami zaciemniającymi do okien wnękowych

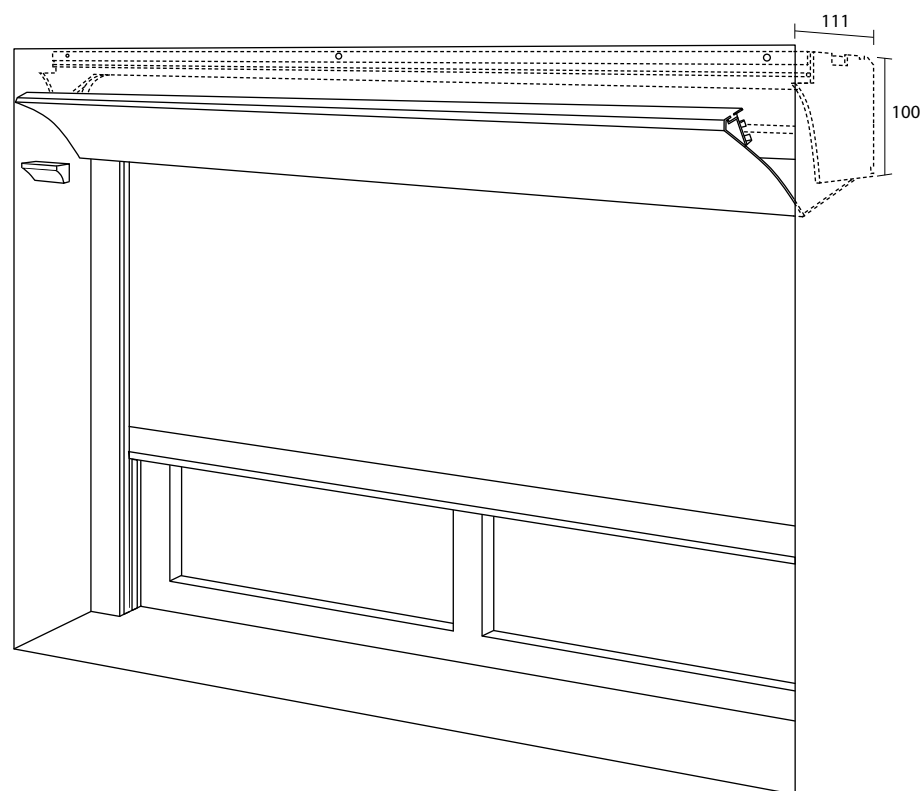

312



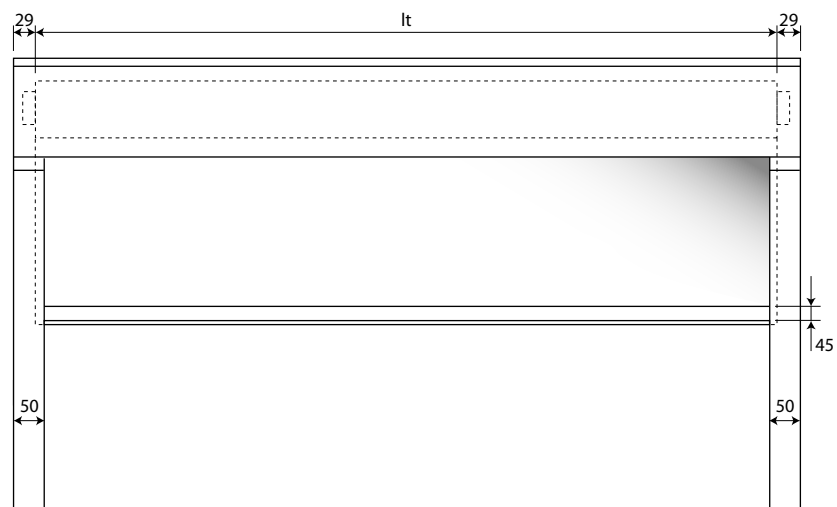

Cod. 103A19...SX / DX*

Cod. 103T19...SX/DX*

Sistema a parete e a soffitto con guide oscuranti per finestra standard
 Wall or ceiling system with blackout guides for standard window
 Système de face ou plafond avec guides occultantes pour fenêtre standard
 Wand- und Deckensystem mit verdunkelten Führungen für Standardfenster
 Sistema a pared o a techo con guías blackout para ventana standard
 System ścienny lub suftowy z szynami zaciemniającymi do okien standardowych

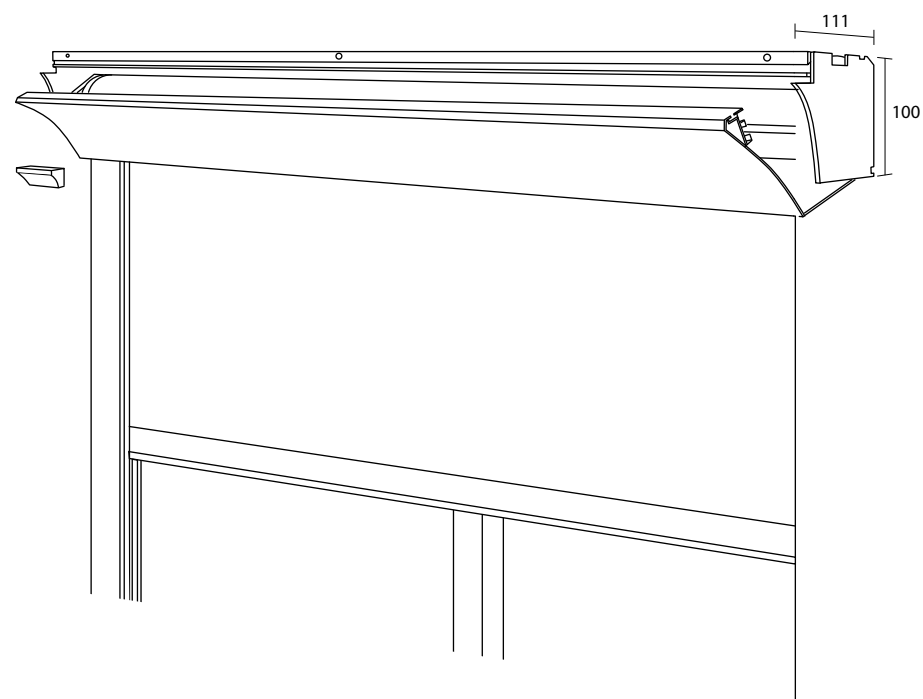

FIN 312

L - cm CT	80						100						120						140					
	A	B	C	D	E	F	A	B	C	D	E	F	A	B	C	D	E	F	A	B	C	D	E	F
120	C - cm																							
140																								
160																								
180																								
200																								
220																								
240																								
260																								
280																								
300																								

L - cm CT	160						180						200						220					
	A	B	C	D	E	F	A	B	C	D	E	F	A	B	C	D	E	F	A	B	C	D	E	F
120	C - cm																							
140																								
160																								
180																								
200																								
220																								
240																								
260																								
280																								
300																								

L - cm CT	240						260						280											
	A	B	C	D	E	F	A	B	C	D	E	F	A	B	C	D	E	F						
120	C - cm																							
140																								
160																								
180																								
200																								
220																								
240																								
260																								
280																								
300																								

Sistema solo motorizzato. Prezzo motore escluso (pag 1-M) - Motorized system only. Price of the motor not included (see page 1-M)
 Système uniquement motorisé. Prix moteur non inclus (voir page 1-M - System nur motorisiert. Preis für Motor nicht enthalten (Seite 1-M)
 Sistema sólo motorizado. Precio motor no incluido (ver página 1-M) - Tylko system zmotoryzowany. Cena silnika nie jest wliczona (pag 1-M)

Maggiorazioni - Surcharges - Suppléments - Zuschläge - Suplementos - Dodatkowo

Coppia guide laterali - Pair of side guides - Paire de guides latérales - Paar seitliche Führungen - Par de guías laterales - Para prowadnic bocznych

L - cm	80	100	120	140	160	180	200	220	240	260	280

FIN = Finitura - Finish - Finition - Fertigung - Acabado - Wykończenie
 L = Larghezza sistema (cm) - System width (cm) - Largeur système (cm) - Gesamtbreite (cm) - Ancho sistema (cm) - Szerokość systemu (cm)
 CT = Classe tessuto - Fabric category - Catégorie tissu - Gewebegruppe - Categoría tejido - Klasa tkaniny
 C = Altezza tessuto (cm) - Fabric height (cm) - Hauteur de la toile (cm) - Stoff Höhe (cm) - Altura tejido (cm) - Wysokość tkaniny (cm)

VELA

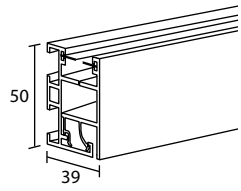

533100

Profilo guida con fissaggio frontale
Guide profile with frontal fixing
Profil guide avec fixation frontale
Führungsprofil mit Frontbefestigung
Perfil guía con fijación frontal
Profil szyny z mocowaniem od przodu

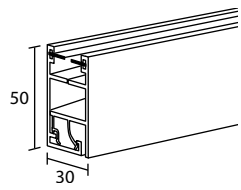

533200

Profilo guida con fissaggio laterale
Guide profile with lateral fixing
Profil guide avec fixation latérale
Führungsprofil mit Seitenbefestigung
Perfil guía con fijación lateral
Profil szyny z mocowaniem bocznym

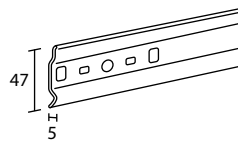

1061

Profilo metallico Metallprofil
Metallic profile Perfil metálico
Profil métallique Profil metalowy

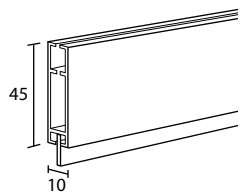

453120

Peso Beschwerungsprofil
Weight bar Perfil contrapeso
Barre de lestage Obciążnik

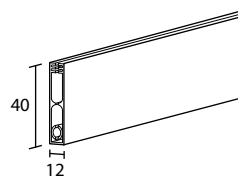

403120

Peso
Weight bar
Barre de lestage
Beschwerungsprofil
Perfil contrapeso
Obciążnik

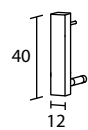

403125

Tappo per peso
Endcap for weight bar
Bouchon pour barre de lestage
Endkappe Für Beschwerungsprofil
Tapón para contrapeso
Zaślepka obciążnika

COMPONENTI - COMPONENTS - COMPOSANTS - ZUBEHÖR - COMPONENTES - CZĘŚCI

Cod.		533100
FIN	L - mt	1
312		

Cod.		533200
FIN	L - mt	1
312		

Cod.		1061
FIN	L - mt	1

Cod.		453120
FIN	L - mt	1
312		

Cod.		403120	403125
FIN	L - mt	1	
312			