







# LEO 30



34-42

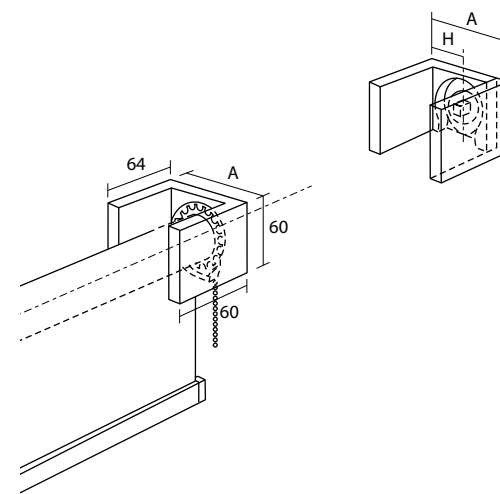
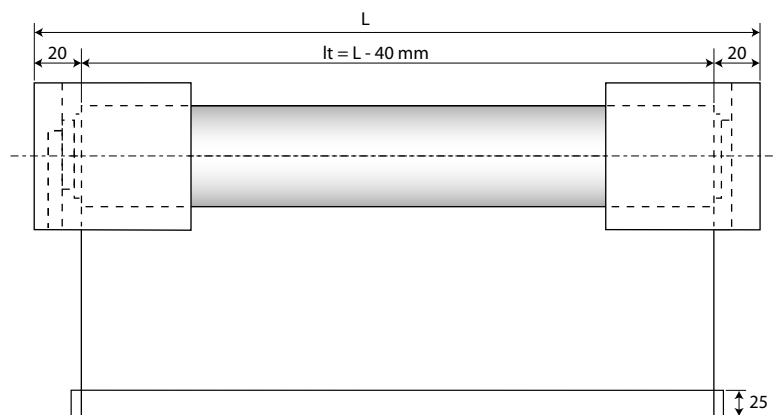

Cod. 863A19...SX / DX

Sistema a parete  
Wall system

Système de face  
Wandmontage

Sistema pared  
System ścienny

Cod.	863419 DX/SX	863439 DX/SX
A - mm	87	137
H - mm	45	95

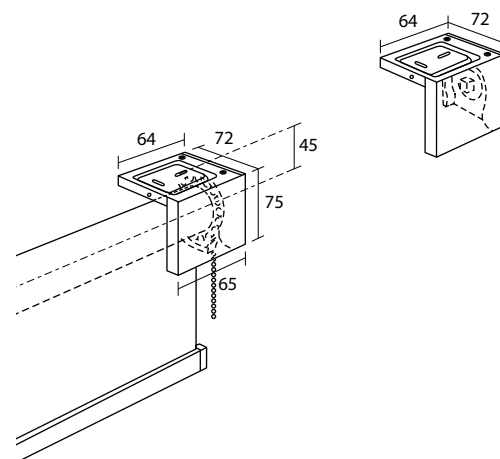
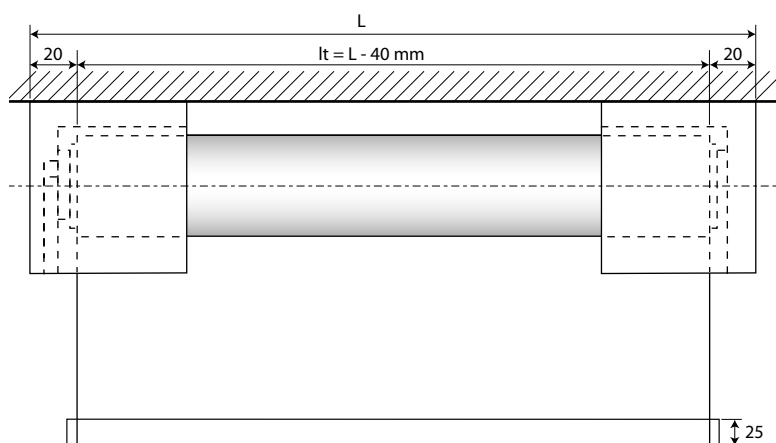

Cod. 863T29...SX / DX

Sistema a soffitto  
Ceiling system

Système plafond  
Deckenmontage

Sistema techo  
System sufitowy



25



67



312

A = Sporgenza supporto - Bracket's projection - Retour support - Träger Abstand - Escuadra de separación - Występ wspornika

H = Distanza parete - Wall distance - Retour du mur - Wand Abstand - Distancia pared - Odległość od ściany

L = Larghezza sistema (cm) - System width (cm) - Largeur système (cm) - Gesamtbreite (cm) - Ancho sistema (cm) - Szerokość systemu (cm)

lt = Larghezza singolo tessuto - Fabric width per unit - Largeur chaque toile - Stoff Breite - Ancho de cada tejido - Szerokość pojedynczej tkaniny



FIN 25 - 312

Supporti - Brackets - Supports - Träger - Soportes - Wsporniki Cod. 863419 - 863439

L - cm CT	80						100						120					
	A	B	C	D	E	F	A	B	C	D	E	F	A	B	C	D	E	F
120	C - cm																	
140																		
160																		
180																		
200																		
220																		
240																		
260																		
280																		
300																		

L - cm CT	140						160						
	A	B	C	D	E	F	A	B	C	D	E	F	
120	C - cm												
140													
160													
180													
200													
220													
240													
260													
280													
300													

Maggiorazioni - Surcharges - Suppléments - Zuschläge - Suplementos - Dodatkowa opłata

L - cm	80	100	120	140	160
67					

FIN = Finitura - Finish - Finition - Fertigung - Acabado - Wykończenie

L = Larghezza sistema (cm) - System width (cm) - Largeur système (cm) - Gesamtbreite (cm) - Ancho sistema (cm) - Szerokość systemu (cm)

CT = Classe tessuto - Fabric category - Catégorie tissu - Gewebegruppe - Categoría tejido - Klasa tkaniny

C = Altezza tessuto (cm) - Fabric height (cm) - Hauteur de la toile (cm) - Stoff Höhe (cm) - Altura tejido (cm) - Wysokość tkaniny (cm)

# LEO 30



34-42

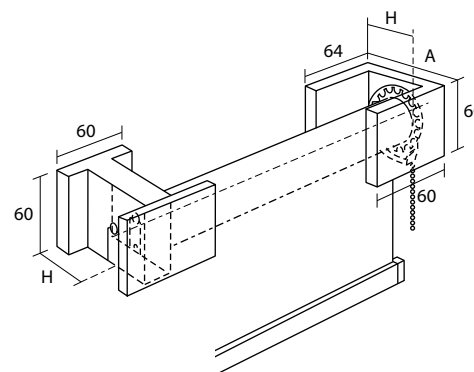
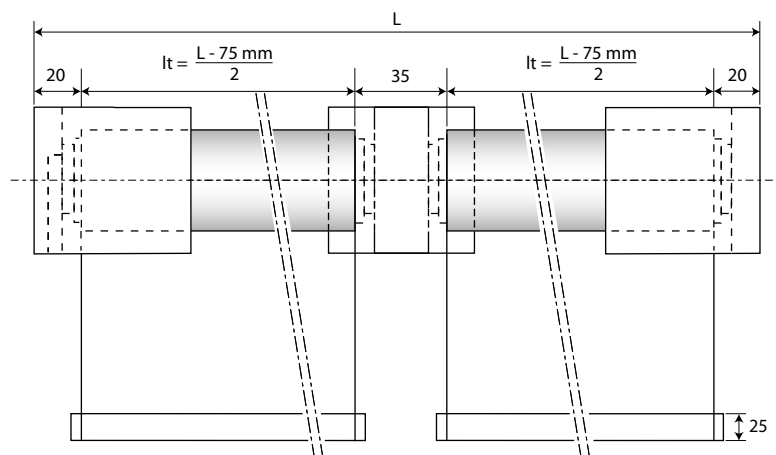
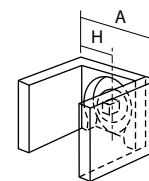

Cod. 863B14...SX / DX

Sistema continuo a parete  
Wall consecutive system

Système continu de face  
Wandsystem mit Seite an Seite Stoffen

Sistema pared continuo  
System ścienny ciągły

Cod.	863614 DX/SX	863664 DX/SX
A - mm	87	137
H - mm	45	95

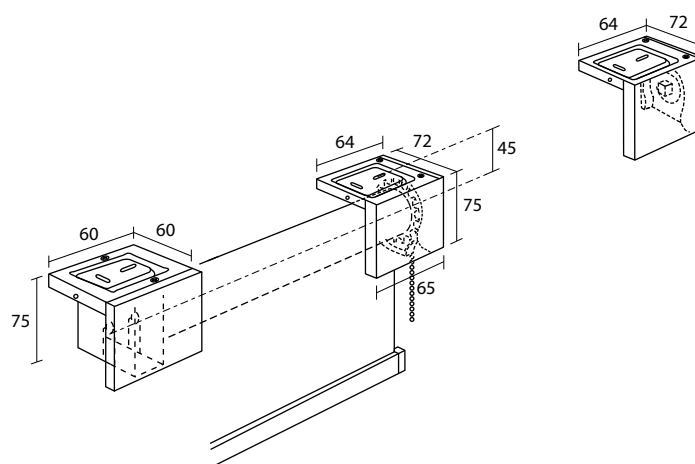
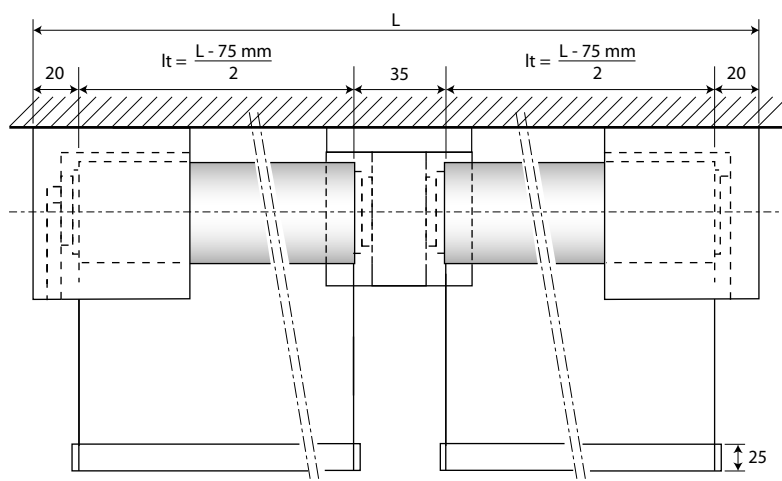

Cod. 863W24...SX / DX

Sistema continuo a soffitto  
Ceiling consecutive system

Système continu plafond  
Deckensystem mit Seite an Seite Stoffen

Sistema continuo techo  
System sufitowy ciągły



25



67



312

A = Sporgenza supporto - Bracket's projection - Retour support - Träger Abstand - Escuadra de separación - Występwpornika  
H = Distanza parete - Wall distance - Retour du mur - Wand Abstand - Distancia pared - Odległość od ściany  
L = Larghezza sistema - System width (cm) - Largeur système (cm) - Gesamtbreite (cm) - Ancho sistema (cm) - Szerokość systemu (cm)  
lt = Larghezza singolo tessuto - Fabric width per unit - Largeur chaque toile - Stoff Breite - Ancho de cada tejido - Szerokość pojedynczej tkaniny



FIN 25 - 312

Supporti - Brackets - Supports - Träger - Soportes - Wsporniki Cod. 863614 - 863664

L - cm CT	160						200						240					
	A	B	C	D	E	F	A	B	C	D	E	F	A	B	C	D	E	F
120	C - cm																	
140																		
160																		
180																		
200																		
220																		
240																		
260																		
280																		
300																		

L - cm CT	280						320						
	A	B	C	D	E	F	A	B	C	D	E	F	
120	C - cm												
140													
160													
180													
200													
220													
240													
260													
280													
300													

Maggiorazioni - Surcharges - Suppléments - Zuschläge - Suplementos - Dodatkowa opłata

67

FIN = Finitura - Finish - Finition - Fertigung - Acabado - Wykończenie

L = Larghezza sistema (cm) - System width (cm) - Largeur système (cm) - Gesamtbreite (cm) - Ancho sistema (cm) - Szerokość systemu (cm)

CT = Classe tessuto - Fabric category - Catégorie tissu - Gewebegruppe - Categoría tejido - Klasa tkaniny

C = Altezza tessuto (cm) - Fabric height (cm) - Hauteur de la toile (cm) - Stoff Höhe (cm) - Altura tejido (cm) - Wysokość tkaniny (cm)

# LEO 30

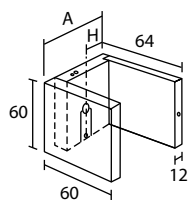

863418 863438

Lato perno  
Pivot side  
Côté pivot  
Träger Achseseite  
Lado pivote  
Strona czopa

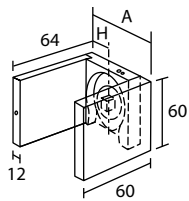

863419 863439

Lato catena  
Chain side  
Côté chainette  
Träger Ketteseite  
Lado cadena  
Strona łańcuszka

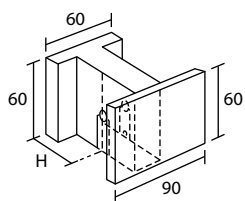

863614 863664

Intermedio P/P  
Middle P/P  
Intermédiaire P/P  
Mittelträger P/P  
Intermedio P/P  
Środkowy P/P

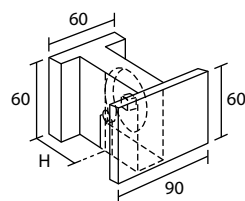

863615 863665

Intermedio P/C  
Middle P/C  
Intermédiaire P/C  
Mittelträger P/C  
Intermedio P/C  
Środkowy P/C

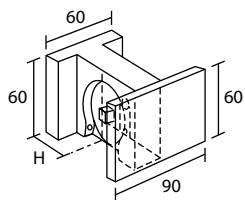

863616 863666

Intermedio C/P  
Middle C/P  
Intermédiaire C/P  
Mittelträger C/P  
Intermedio C/P  
Środkowy C/P

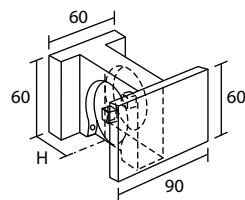

863617 863667

Intermedio C/C  
Middle C/C  
Intermédiaire C/C  
Mittelträger C/C  
Intermedio C/C  
Środkowy C/C

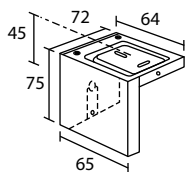

863628

Lato perno  
Pivot side  
Côté pivot  
Träger Achseseite  
Lado pivote  
Strona czopa

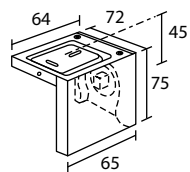

863629

Lato catena  
Chain side  
Côté chainette  
Träger Ketteseite  
Lado cadena  
Strona łańcuszka

P = Lato perno - Pivot side - Côté pivot - Achseseite - Lado Pivote - Strona czopa  
C = Lato catena - Chain side - Côté chainette - Ketteseite - Lado cadena - Strona łańcuszka

SISTEMA A PARETE - WALL SYSTEM - SYSTÈME DE FACE - WANDMONTAGE - SISTEMA PARED - SYSTEM ŚCIENNY

Cod.		863418SX / DX	863438SX / DX	863419SX / DX	863439SX / DX
FIN	A - mm	87	137	87	137
	H - mm	45	95	45	95
25 - 312					
67					

Cod.		863614SX / DX	863664SX / DX	863615SX / DX	863665SX / DX
FIN	A - mm	87	137	87	137
	H - mm	45	95	45	95
25 - 312					
67					

Cod.		863616SX / DX	863666SX / DX	863617SX / DX	863667SX / DX
FIN	A - mm	87	137	87	137
	H - mm	45	95	45	95
25 - 312					
67					

SISTEMA A SOFFITTO - CEILING SYSTEM - SYSTÈME PLAFOND - DECKENMONTAGE - SISTEMA TECHO - SYSTEM SUFITOWY

Cod.		863628SX / DX	863629SX / DX
FIN			
25 - 312			
67			



# LEO 30

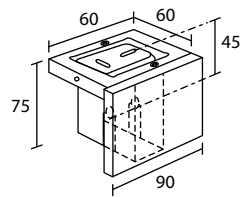

863414  
Intermedio P/P  
Middle P/P  
Intermédiaire P/P  
Mittelträger P/P  
Intermedio P/P  
Środkowy P/P

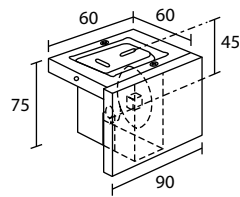

863415  
Intermedio P/C  
Middle P/C  
Intermédiaire P/C  
Mittelträger P/C  
Intermedio P/C  
Środkowy P/C

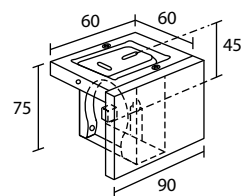

863424  
Intermedio C/P  
Middle C/P  
Intermédiaire C/P  
Mittelträger C/P  
Intermedio C/P  
Środkowy C/P

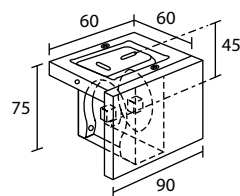

863425  
Intermedio C/C  
Middle C/C  
Intermédiaire C/C  
Mittelträger C/C  
Intermedio C/C  
Środkowy C/C

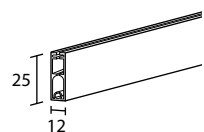

253120  
Peso  
Weight bar  
Barre de lestage

Beschwerungsprofil  
Perfil contrapeso  
Obciążnik



253135  
Tappo per peso  
Endcap for weight bar  
Bouchon pour barre de lestage  
Endkappe Für Beschwerungsprofil  
Tapón para contrapeso  
Zaślepka obciążnika

P = Lato perno - Pivot side - Côté pivot - Achseseite - Lado Pivote - Strona czopa  
C = Lato catena - Chain side - Côté chainette - Ketteseite - Lado cadena - Strona łańcuszka

SISTEMA A SOFFITTO - CEILING SYSTEM - SYSTÈME PLAFOND - DECKENMONTAGE - SISTEMATECHO - SYSTEM SUFITOWY

<b>Cod.</b>	<b>863414SX / DX</b>	<b>863415SX / DX</b>
<b>FIN</b>		
<b>25 - 312</b>		
<b>67</b>		

<b>Cod.</b>	<b>863424SX / DX</b>	<b>863425SX / DX</b>
<b>FIN</b>		
<b>25 - 312</b>		
<b>67</b>		

COMPONENTI - COMPONENTS - COMPOSANTS - ZUBEHÖR - COMPONENTES - CZĘŚCI

<b>Cod.</b>	<b>253120</b>
<b>FIN</b>	<b>L - mt</b>
<b>25 - 312</b>	<b>1</b>
<b>67</b>	

<b>Cod.</b>	<b>253135</b>
<b>FIN</b>	
<b>25 - 312</b>	
<b>67</b>	